

# High Voltage Stackable User Manuel

## MatchBox HVS



Product Name: MatchBox HVS

Model No: HVS PACK - 2 / 3 / 4 / 5 / 6 / 7

Version No: V1.1

## Content

1. Statement of Law .....	1
2. Safety Guidelines .....	1
2.1. Main precautions .....	1
2.2. Symbols .....	2
2.3. Abbreviations Used in this Manual. ....	2
2.4. Note Before Installation .....	2
2.5. During Operation .....	3
3. System Application Introduction .....	3
3.1. Product Properties .....	3
3.2. PV Self-use Surplus Power to Grid .....	4
3.3. Peak Shaving and Valley Filling .....	4
3.4. Standby Power Supply .....	4
4. Product Specification .....	5
4.1. System Performance Parameter .....	5
4.2. Inverter Connection Cables .....	6
4.3. System Drawing .....	6
4.4. Battery Controller Box .....	8
4.5. Battery Pack .....	10
4.6. Wi-Fi Antenna .....	11
4.7. Display rendering .....	13
5. System Installation Instructions .....	13
5.1. Installation location .....	13
5.2. Installation Tools .....	14
5.3. Unpacking inspection .....	14
5.4. Packing List .....	15
5.5. Handling and Placement .....	15
5.6. Battery system self-test .....	16
5.7. Shut down .....	16
5.8. Connecting inverter .....	16
5.9. Storage Recommendations .....	16
6. Inverter Connection Diagram .....	17
6.1. With Solinteg .....	17
7. Appendix1 .....	17
8. Appendix2 .....	19
8.1. Abnormal Situation Addressing .....	19
8.2. Product Responsibilities and Consulting .....	20

## 1. Statement of Law

Copyright of this document belongs to BSLBATT(Huizhou) Co., Ltd.

No part of this documentation may be excerpted, reproduced, translated, annotated, or duplicated in any form or by any means without the prior written authorization of BSLBATT(Huizhou) Co., Ltd. All Rights Reserved.

This product complies with the design requirements of environmental protection and personal safety. The storage, use and disposal of the products shall be carried out in accordance with the product manual, relevant contract or relevant laws and regulations.

Customer can check the related information on the website of BSLBATT(Huizhou) Co., Ltd. when the product or technology is updated.

Web URL : <https://www.bsl-battery.com/>







Please note that the product can be modified without prior notification.

## 2. Safety Guidelines

### 2.1. Main precautions

- ◆ It is very important and necessary to read the user manual carefully before installing or using the battery. Failure to follow any of the instructions or warnings in this document can result in electrical shock, serious injury, or may damage the battery and the whole system.
- ◆ The battery needs to be recharged within 12 hours after fully discharging.
- ◆ Do not expose cable outside.
- ◆ All battery terminals must be disconnected before maintenance.
- ◆ Do not use cleaning solvents to clean the battery.
- ◆ Do not expose the battery to flammable or harsh chemicals or vapors.
- ◆ Any foreign object is prohibited to be inserted into any part of the battery.
- ◆ Any warranty claims are excluded for direct or indirect damage due to items above.
- ◆ Only qualified person can perform the wiring of the battery strings.
- ◆ If the battery is stored for a prolonged time, it is requirement that they are charged every three months, and the SOC should be no less than 50%.

## 2.2. Symbols

Symbol	Description
	Caution, risk of electric shock
	Heavy enough may cause severe injury
	Keep the battery away from open flame or ignition sources
	Keep the battery away from children
	Do not dispose of the product with household waste
	Recycling
	Read this manual before installation and operation

## 2.3. Abbreviations Used in this Manual.

Abbreviation	Designation
BSL	BSLBATT(Huizhou) Co., Ltd
QC	Quality Control
BMS	Battery Management System
PCS	Power Conversion System
SOC	State of Charge
UPS	Uninterruptible Power Supply
BESS	Battery Energy Storage System
EMS	Energy Management System
BCU	Battery control unit
BMU	Battery Management Unit
BAU	Battery array unit

## 2.4. Note Before Installation

- ◆ When receiving, please check the system and packing list first, if the pack is damaged or spare parts are missing, please contact the dealer.
- ◆ Before installation, be sure to cut off the grid power and make sure the battery is in the turned-off mode.
- ◆ Wiring must be correct, do not mix-connect the positive and negative cables, and ensure no short circuit with the external device.
- ◆ It is prohibited to connect the battery to AC power directly without an AC Breaker.
- ◆ Please ensure the electrical parameters of AC power and Load are compatible to system.
- ◆ Keep the system away from fire or water.

- ◆ Battery is for indoor installation only.

### 2.5. During Operation

- ◆ If the system needs to be moved or repaired, the power must be cut off first and the battery is completely shut down.
- ◆ It is prohibited to connect the system with different type of battery.
- ◆ It is prohibited to put the batteries working with faulty or incompatible inverter.
- ◆ In case of fire, only dry powder fire extinguisher can be used, liquid fire extinguishers are prohibited.
- ◆ Please do not open, repair, or disassemble the system except staffs from BSLBATT or authorized by BSLBATT. We do not undertake any consequences or related responsibility due to violation of safety operation or violating of design, production, and equipment safety standards.

## 3. System Application Introduction

This product is a household energy storage battery pack. The system is matched with a 10.64/15.97/21.29/26.62/31.94/37.27kwh lithium iron phosphate battery pack. This product can be used in conjunction with electricity, so that electricity consumption can be adjusted. This product supports a variety of application modes, such as PV self-use surplus power to grid, peak shaving and valley filling, standby power supply, etc. The specific operation logic is as follows.

### 3.1. Product Properties

- ◆ Anode material is made from LiFePO<sub>4</sub> with safety performance and long cycle life.
- ◆ Battery management system (BMS) has protection functions including over-discharge, over-charge, over-current and high/low temperature.
- ◆ The system can automatically manage charge and discharge state and balance current and voltage of each cell.
- ◆ Flexible configuration, multiple battery modules can be in serial for expanding voltage and Capacity.
- ◆ Triple protection mechanism, including relays, fuse, and circuit breaker, preventing battery from short circuits or other serious malfunctions.
- ◆ Standard intelligent gateway for remote battery monitoring and diagnosis.
- ◆ Good ventilation and cooling capacity, the battery pack will not generate heat accumulation.
- ◆ Working temperature range is from 0 to 50°C, with excellent discharge performance and cycle life.
- ◆ Small size and light weight, standard module is comfortable for installation and maintenance.

### 3.2. PV Self-use Surplus Power to Grid

Under the condition of good illumination in the daytime, the DC power from PV panel is changed into AC through inverter to supply power for household load. If the household load cannot run out of photovoltaic power, the remaining power will be stored in the battery. If the battery is full, photovoltaic power will be supplied to the grid. In the night or rainy days, photovoltaic cannot generate electricity. The battery supplies power to the home load through an inverter. If the battery SOC is low, the household load will take power from the grid.

### 3.3. Peak Shaving and Valley Filling

In some countries and regions where peak valley time of use price is implemented, if the difference between peak price and low price is large, the application mode of peak shaving and valley filling can be adopted in energy storage system. In the low electricity price period, the energy storage system is charged; in the peak period of electricity price, the energy storage system supplies power to the household load. It can avoid users using too much power grid when the electricity price is high and save energy expenditure.

### 3.4. Standby Power Supply

In some extreme weather (such as tornadoes, typhoons, hail), or substation operation failure, power supply will be interrupted. If the energy storage system is installed, the user can still enjoy sufficient power guarantee under this situation.

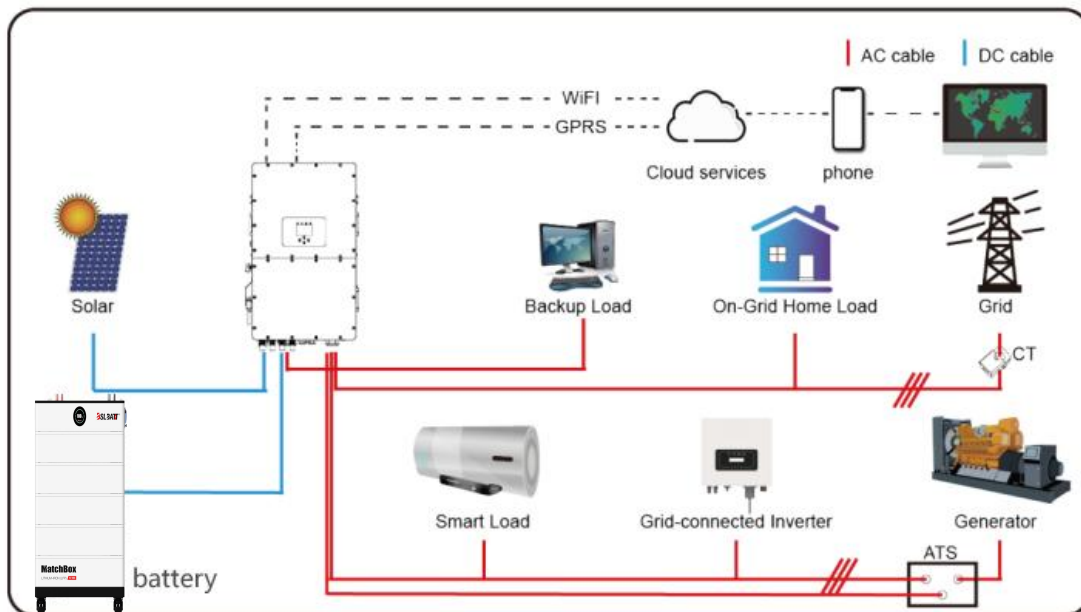

System Connection Diagram

## 4. Product Specification

**HVS-PACK** is a high voltage battery storage system based on lithium iron phosphate battery, which is one of the new energy storage products developed and produced by BSLBATT. It can be used to provide reliable power for various types of equipment and systems. **HVS-PACK** enables multiple strings parallel operation feature, which provides tremendous flexibility in system design and configuration. **HVS-PACK** is especially suitable for those application scenes which require flexible capacity extension, high power output, limited installation space, restricted load-bearing and long cycle life.

### 4.1. System Performance Parameter

No	General Parameter	HVS 2	HVS 3	HVS 4
1	Rated Voltage	204.8V	307.2V	409.6V
2	Rated Capacity	52Ah	52Ah	52Ah
3	Cell Brand (LFP-3.2V)	REPT52AH	REPT52AH	REPT52AH
4	System configuration	64S1P	96S1P	128S1P
5	Battery single box number	2pack+1 control box	3 pack+1 control box	4pack+1 control box
6	Rated power	10.64kWh	15.97kWh	21.29kWh
7	Charge Upper Voltage	227.2V	340.8V	454.4V
8	Discharge Lower Voltage	182.4V	273.6V	364.8V
9	Recommended Current	26A	26A	26A
10	Maximum Charging Current	52A	52A	52A
11	Maximum Discharging Current	52A	52A	52A
12	Dimension (W*D*H, mm)	665*370*425	665*370*575	665*370*725
13	Communication protocol	CANBUS (Baud rate @500Kb/s or @250Kb/s)/Modbus RTU(@9600b/s)		
14	Host software protocol	CANBUS (Baud rate @250Kb/s)		
15	Cloud platform	Bluetooth/wifi		
16	Operation Temperature Range	Charge:0~55℃		
17		Discharge: -20~55℃		
18	Cycle Life(25℃)	6000@80%SOH		
19	Protection level	IP54		
20	Storage Temperature	-10℃~40℃		
21	Storage Humidity	10%RH ~90%RH		
<b>Note: Parameters can be adjusted according to customer requirements</b>				

No	General Parameter	HVS 5	HVS 6	HVS 7
1	Rated Voltage	512V	614.4V	718.8V
2	Rated Capacity	52AH	52AH	52AH
3	Cell Brand (LFP-3.2V)	REPT52AH	REPT52AH	REPT52AH
4	System configuration	160S1P	192S1P	224S1P
5	System composition	5pack+1 control box	6 pack+1 control box	7 pack+1 control box
6	Rated power	26.62kWh	31.94kWh	37.27kWh
7	Charge Upper Voltage	568V	681.6V	795.2V
8	Discharge Lower Voltage	456V	547.2V	645.12V
9	Recommended Current	26A	26A	26A
10	Maximum Charging Current	52A	52A	52A
11	Maximum Discharging Current	52A	52A	52A
12	Dimension (W*D*H, mm)	665*370*875	665*370*1025	665*370*1175
13	Communication protocol	CANBUS (Baud rate @500Kb/s or @250Kb/s)/Modbus RTU(@9600b/s)		
14	Host software protocol	CANBUS (Baud rate @250Kb/s)		
15	Cloud platform	Bluetooth/wifi		
16	Operation Temperature Range	Charge:0~55℃		
17		Discharge: -20~55℃		
18	Cycle Life(25℃)	6000@80%SOH		
19	Protection level	IP54		
20	Storage Temperature	-10℃~40℃		
21	Storage Humidity	10%RH ~90%RH		
<b>Note: Parameters can be adjusted according to customer requirements</b>				

#### 4.2. Inverter Connection Cables

We will provide cables according to the actual situation of the customer. But if the customer wants to provide their own cables, they can refer to the following table.

No	Matched Inverter	Wire size	Cable(mm <sup>2</sup> )	Recommended Quantity
1	Solinteg	AWG4~AWG6	8.8~13.3	1 positive cables+1negative cables

#### 4.3. System Drawing



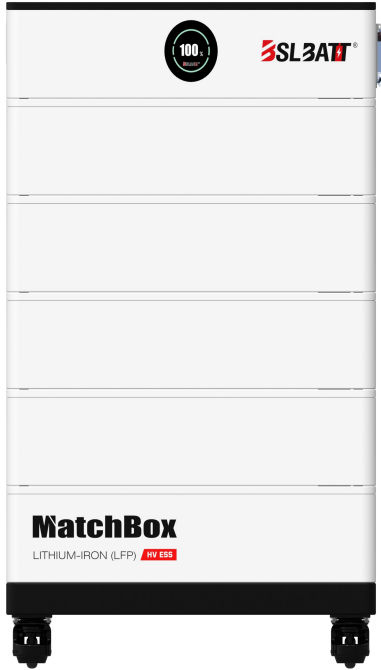

#### 4.4. Battery Controller Box

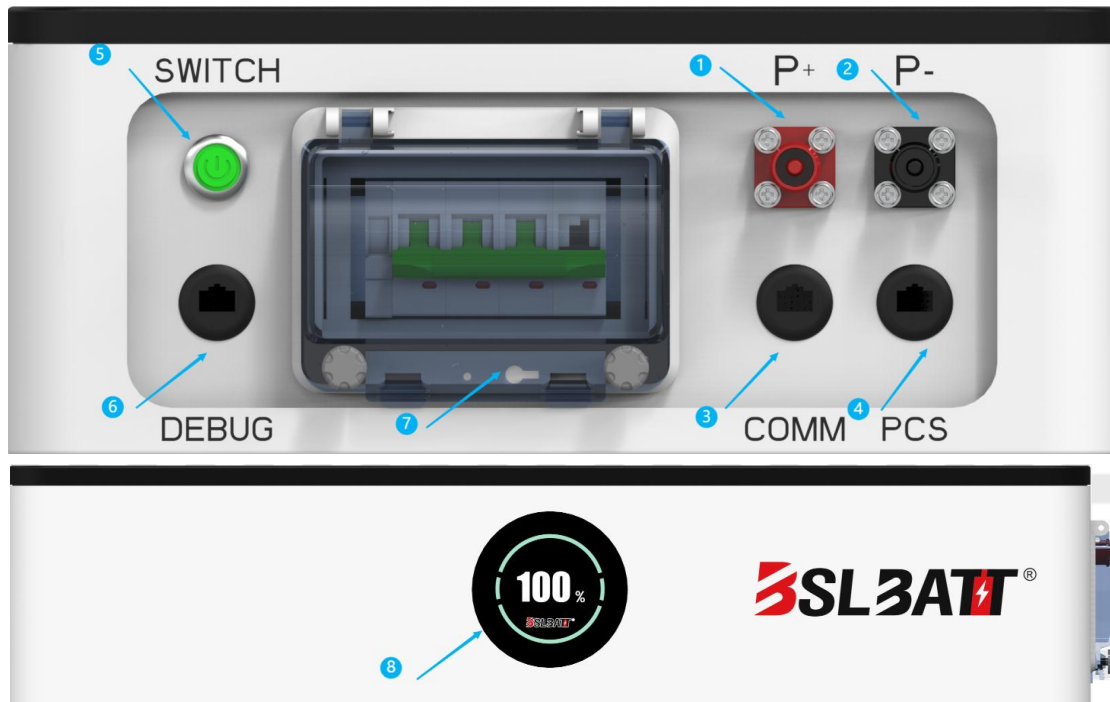

Item	Name	Definition
1	External Positive socket	Connect battery system with Inverter positive terminal
2	External Negative socket	Connect battery system with Inverter negative terminal
3	Parallel communication port	Address confirmation for parallel connection with another HVS-PACK
4	PCS communication port	Communicate battery controller with inverter
5	Power On Button	Used to control the on/off of the low voltage circuit of the battery
6	Debugging port	Communicate to computer for monitoring and upgrading battery
7	DC circuit breaker	Used to control the on/off of the high-voltage circuit of the battery
8	Screen	For detecting the battery status



**Caution:** When the DC breaker is tripped off because of over current or short circuit, must wait after 30min to turn on it again, otherwise may cause the breaker damage.



**Power On Button:** Generally when it is at ON state, you can't turn off it during normal running condition.

**Danger:** Ensure Power On Switch is turned on before waking up the battery. Otherwise it will affect automatic checking process and cause danger.



**Danger:** DO NOT turn off the " Power On Switch" during normal running condition, only in emergency case it could be turned off directly. Otherwise will cause this battery string current surge by another battery strings.

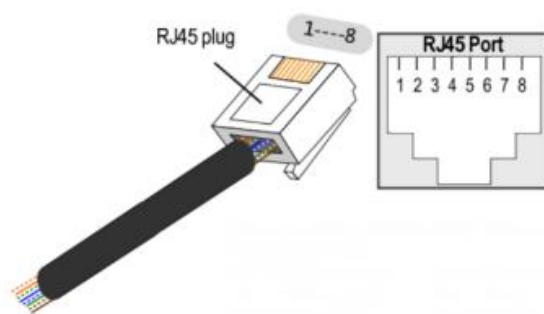
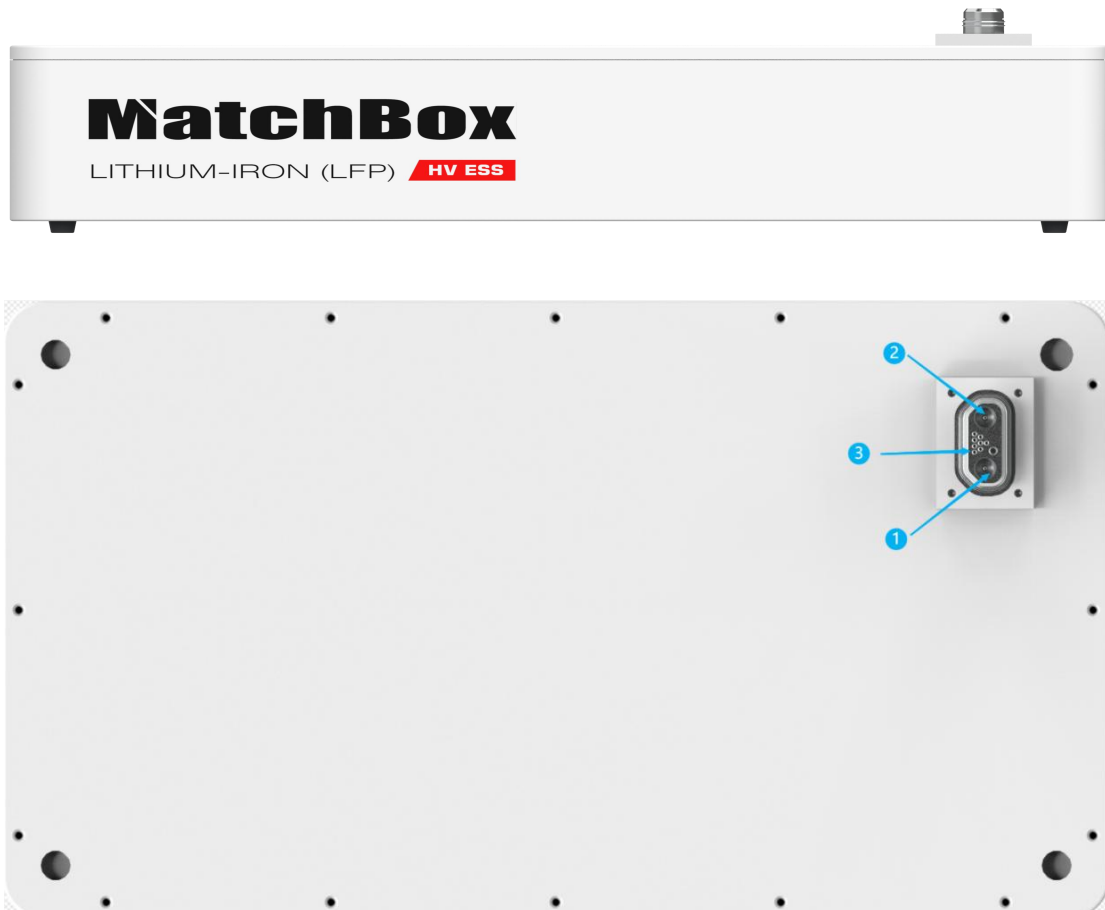

Figure 2. Definition of "PCS" " Debug" port pin

PIN	Color	Definition (PCS)	Definition (Debug)
1	Orange/White	NC	RS485A
2	Orange	NC	RS485B
3	Green/White	CANG	NC
4	Blue	CANH	CANH
5	Blue/White	CANL	CANL
6	Green	NC	NC
7	Brown/White	NC	NC
8	Brown	NC	NC

4.5. Battery Pack



Item	Name	Definition
1	Pack positive socket	Positive terminal of battery pack
2	Pack negative socket	Negative terminal of battery pack
3	Internal communication(out)	Connected to lower layer battery box

## 4.6. Wi-Fi Antenna

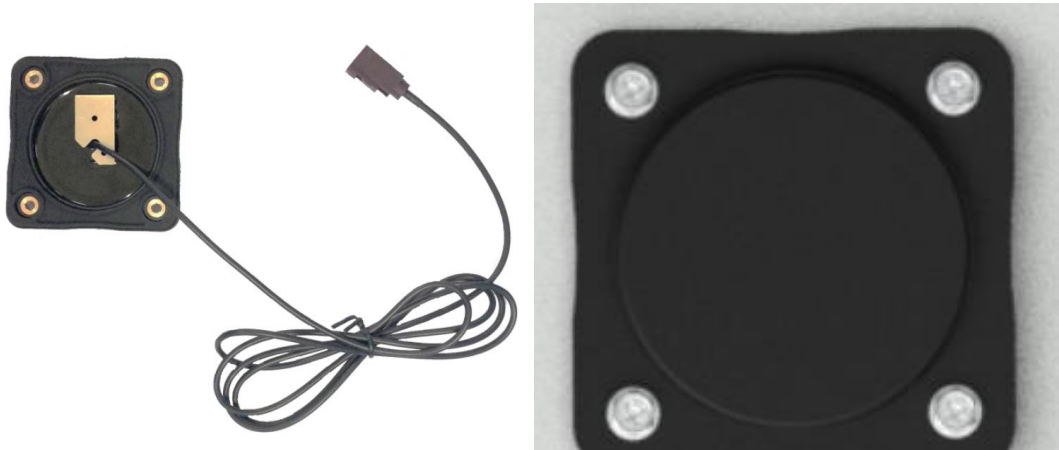

Before we could check the details of battery through APP or WEB, we shall connect the antenna to WIFI:

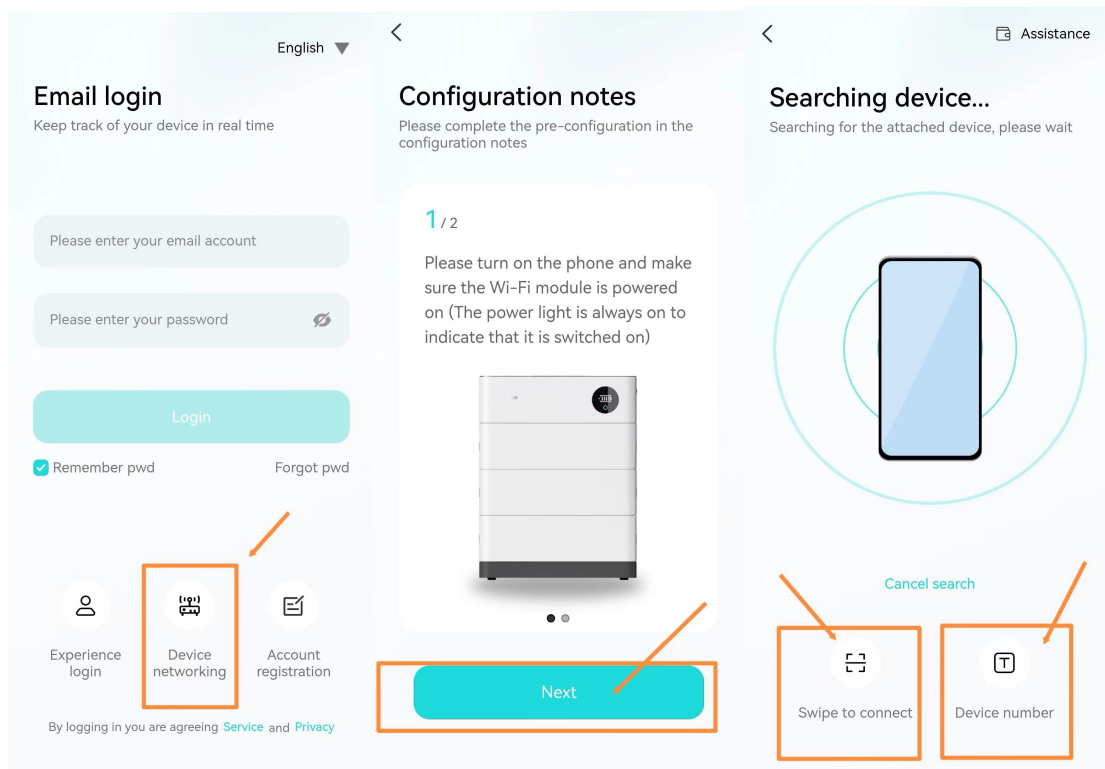

(Tips: if fail to search device by Bluetooth, you can try scanning the code or directly entering the device number, all this information is on the sticker next to the antenna)

## HVS-PACK User Manual

Battery data can be uploaded to the cloud platform after the antenna successfully connected to the WIFI:

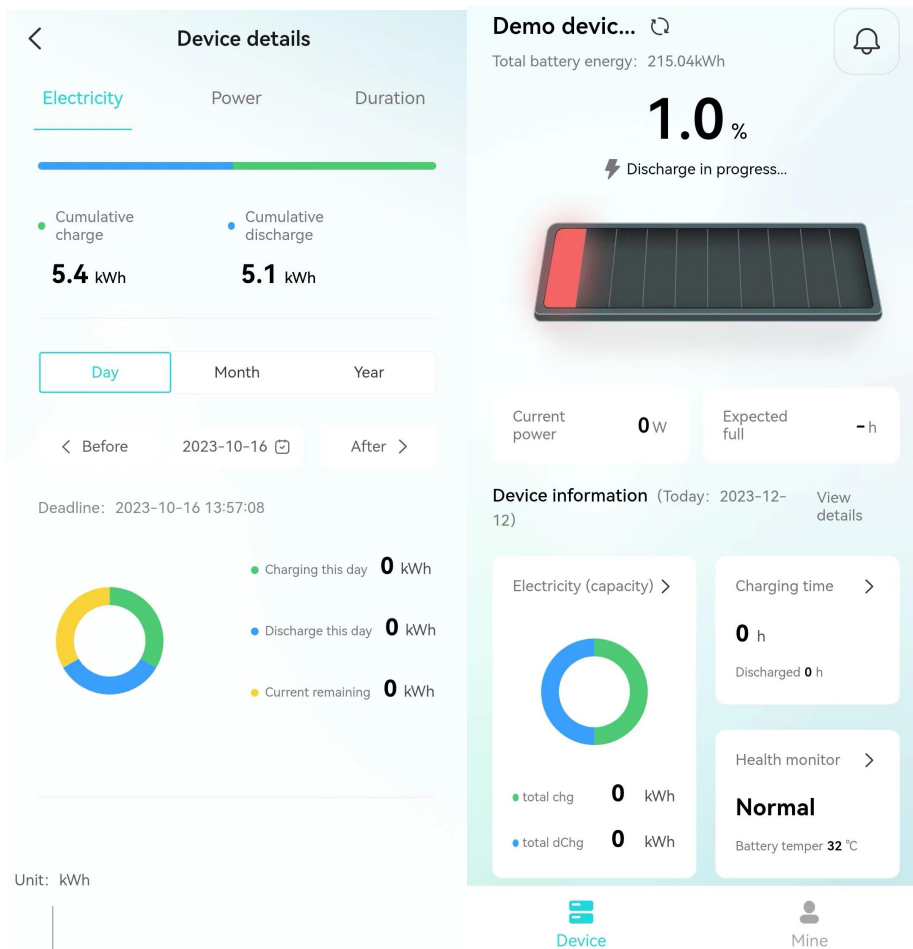

Unit: kWh

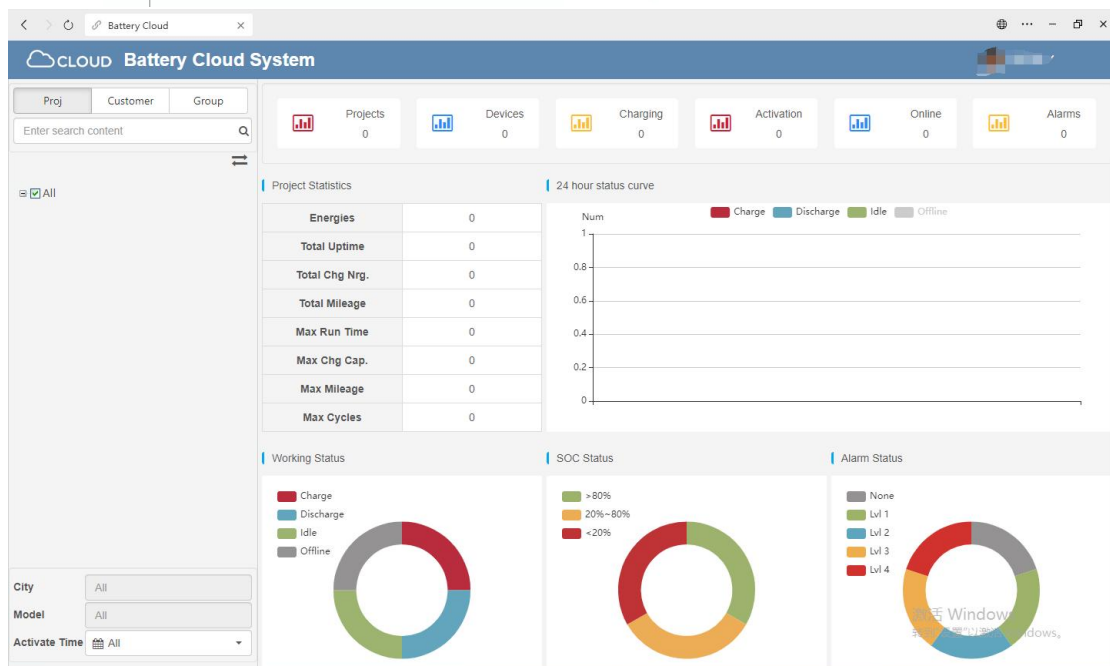

#### 4.7. Display rendering



Battery Management System (BMS) information can be directly read and indicated by display.

## 5. System Installation Instructions

### 5.1. Installation location

Make sure that the installation location meets the following conditions:

- ◆ The building is designed to withstand earthquakes.
- ◆ Far away from the sea to avoid salt water and humidity.
- ◆ The floor is flat.
- ◆ No flammable or explosive materials nearby.
- ◆ Optimal ambient temperature is between 25°C and 55°C.
- ◆ Temperature and humidity stay at a constant level.
- ◆ Minimal dust and dirt in the area.
- ◆ No corrosive gases present, including ammonia and acid vapor.

The system could be installed indoor. If the ambient temperature is outside the operating range, battery will protect itself by shutting down. The system optimal operate temperature is 0°C to 55°C. Before installation and system power on, the dust and iron scurf must be removed to keep a clean environment. And the environment must have certain anti-dust ability. Frequent exposure to severe operating condition would exacerbate the performance and lifetime of the system.









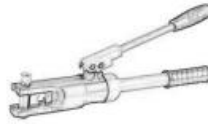

**NOTICE**

Make sure that the cross-sectional area of charging cables is 25 to 35 mm<sup>2</sup>

A breaker between BSL battery and inverter was recommended to install and the breakers min. current should meet twice the rated current of the system or following with local regulations.

**5.2. Installation Tools**

To install the battery pack, those following tools are probably required:

			
Phillips screwdriver	Torque wrench	Cable crimper	Wire clamp
			
Voltmeter	Tape measure	Drill	Flat-head screwdriver
			
Insulated glove	Safety goggles	Safety shoes	

**5.3. Unpacking inspection**





- ◆ When the equipment arrives at the installation site, loading and unloading should be performed according to the rules and regulations, to prevent from being exposed under sunlight. Battery should not be installed in direct sunlight.



## HVS-PACK User Manual

- ◆ Before unpacking, the total number of packages shall be indicated according to the shipping list attached to each package, and the case shall be checked for good condition.
- ◆ In the process of unpacking, handle with care and protect the surface coating of the object.
- ◆ Open the package, the installation personnel should read the technical documents, verify the list, according to the configuration table and packing list, ensure objects are complete and intact, if the internal packing is damaged, should be examined and recorded in detail.

### 5.4. Packing List

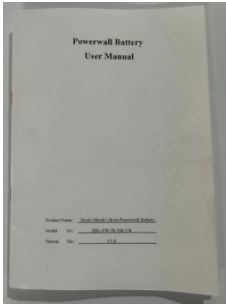
Battery mounting bracket	Battery Controller Box	Battery Pack
		
Power cable	Communication cable	User's manual
		

### 5.5. Handling and Placement

- ◆ The battery pile's power terminals have high DC voltage. It must be installed in a restricted access area.
- ◆ HVS-PACK is a high voltage DC system, operated by qualified and authorized personnel only.
- ◆ Single battery pack is quite heavy. The battery pack must be handled by more than 2 personnel if there're no handling tools.
- ◆ HVS-PACK system working temperature range:  $-20^{\circ}\text{C}\sim 55^{\circ}\text{C}$ ; Optimum temperature:  $18^{\circ}\text{C}\sim 28^{\circ}\text{C}$ . DO NOT expose the battery system to direct sun light. It is suggested to build sunshade equipment. In cold area a heating system is required.

- ◆ HVS-PACK system must not be immersed in water. The battery base cannot be exposed to rain or other water sources. As a suggestion, the base's height shall be >300mm above the ground.
- ◆ The support surface should have sufficient load capacity to support the weight of whole battery system(>2T).
- ◆ HVS-PACK system must be installed on a fixed and flat support surface.

### 5.6. Battery system self-test

**Step1:** Check if all battery wiring is correct.

**Step2:** Turn on the DC breaker.

**Step3:** Press the circular metal switch to "on" status.

**Step4:** Check if any alarm information is displayed on the screen, if so, please contact your installer or BSLATT.

### 5.7. Shut down

**Step1:** Press the circular metal switch to "off" status.

**Step2:** Turn off the DC breaker.

### 5.8. Connecting inverter

- ◆ An external DC Breaker that operates both positive and negative conductors simultaneously between the battery controller and inverter on the power cable is recommended. After waking up the battery controller and ensure that the battery controller is pre-charged, you can turn on it.
- ◆ Please confirm that the battery system is in the off state before connecting. It maybe causes electric shock to personnel and damage to the inverter if connect the battery directly without power off.
- ◆ When connecting to the inverter's battery port, ensure that the positive and negative cables are not reversed.

### 5.9. Storage Recommendations

- ◆ For long-term storage (more than 3 months), the battery cells should be stored in the environment: temperature range of 5~45°C, relative humidity<65%and contains non-corrosive gas.
- ◆ The battery module should arrange in range of 5~45°C, dry, clean, and well-ventilated environment. The battery should be charged to 50~55% SOC before storage.
- ◆ It is recommended to active the battery system (discharge and charge) every 3 months, and the longest duration of storage without charge and discharge cannot exceed 6 months.

Caution: The cycle life of the battery will have relative heavily reduction if not follow the above instructions to store the battery for a long term.

## 6. Inverter Connection Diagram

### 6.1. With Solinteg

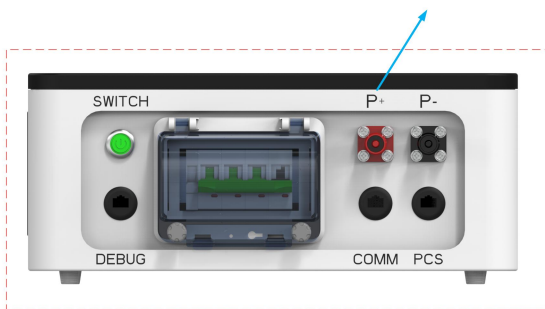
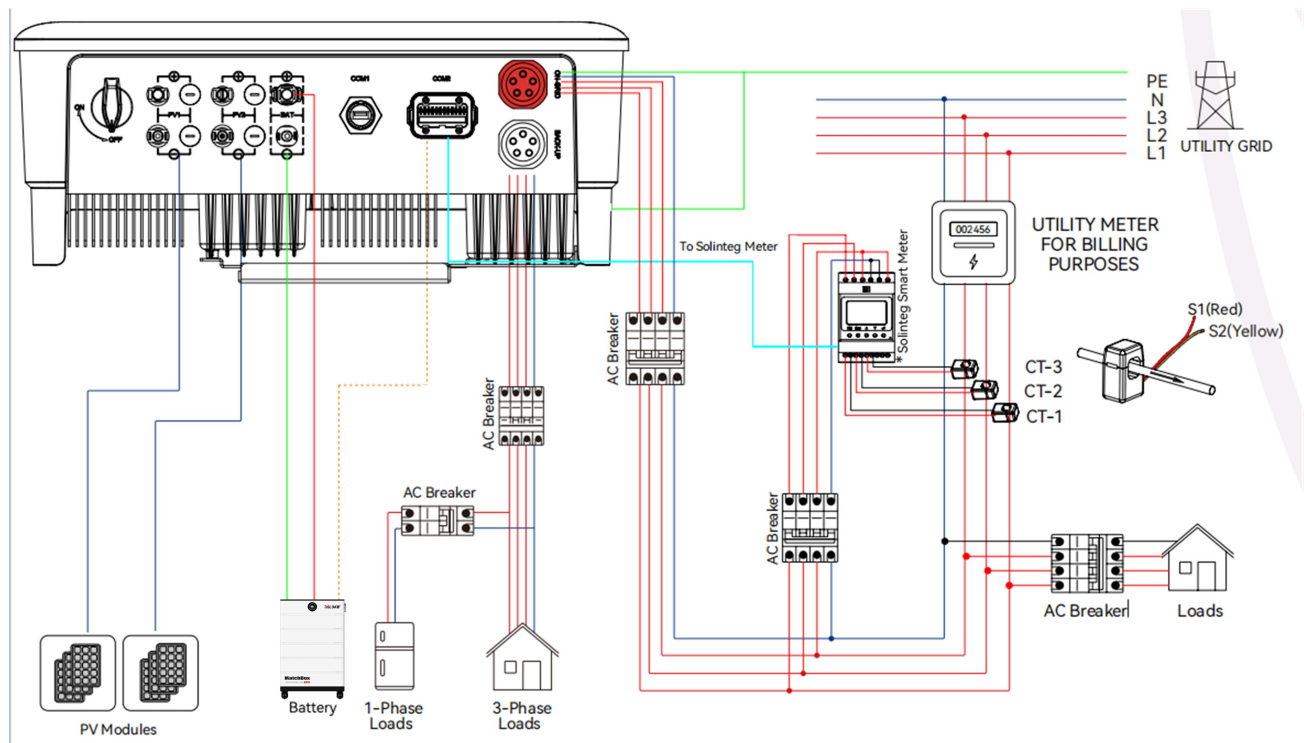

## 7. Appendix1

When the equipment manufacturer confirms that it is necessary for customer to set the battery parameter, it can authorize to provide the customer with the host software and operating instructions.

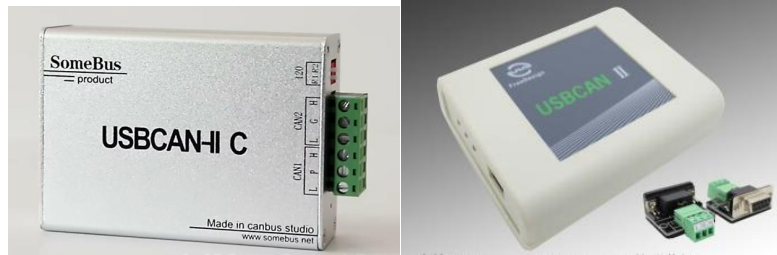

CAN Serial port communication device

Host soft operation:

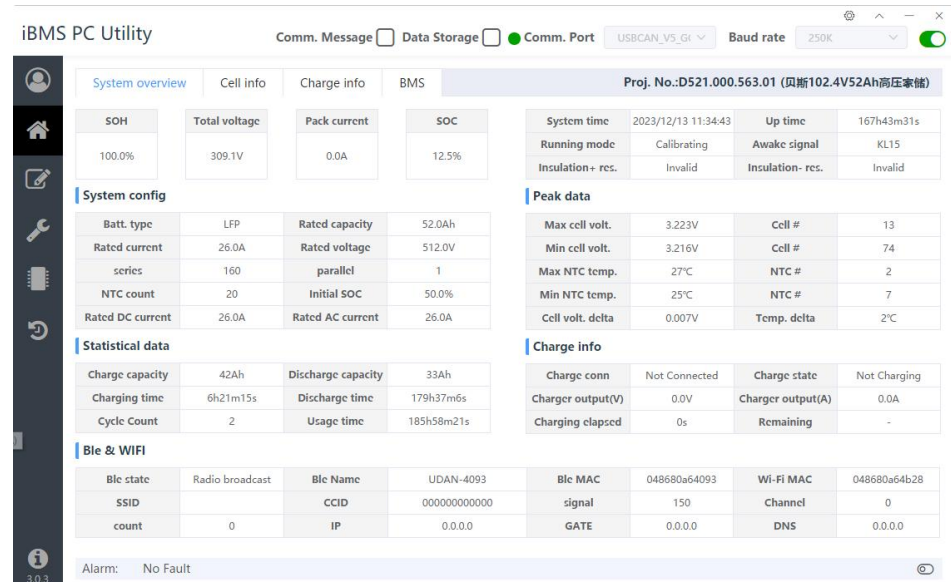
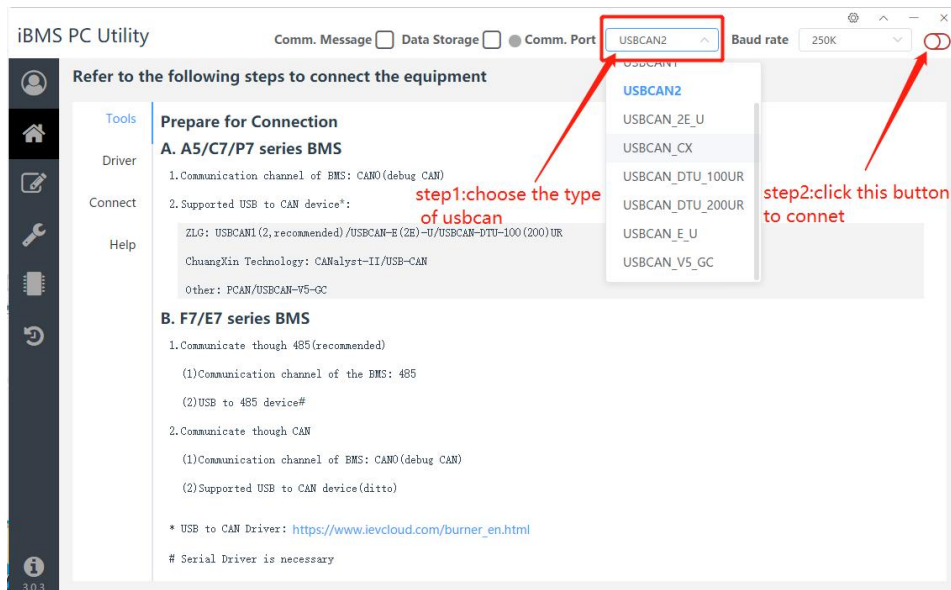

BMU	B1	B2	B3	B4	B5	B6	B7	B8	B9	B10	B11	B12	B13	B14	B15	B16	B17	B18	T1	T2	T3	T4	T5	T6	T7	T8	T9
BMU-1	3220	3221	3221	3222	3221	3220	3221	3222	3220	3220	3220	3220	3223	3220	3220	3221	NC	NC	26	27	NC	NC	NC	NC	NC	NC	NC
PortA	3220	3220	3220	3220	3222	3220	3220	3219	3219	3221	3220	3220	3220	3218	3219	3221	NC	NC	27	27	NC	NC	NC	NC	NC	NC	NC
PortB	3220	3220	3219	3221	3220	3220	3221	3218	3220	3222	3221	3219	3220	3221	3221	3220	NC	NC	25	26	NC	NC	NC	NC	NC	NC	NC
BMU-2	3221	3220	3219	3220	3220	3221	3219	3219	3220	3221	3220	3220	3221	3221	3220	3220	NC	NC	26	26	NC	NC	NC	NC	NC	NC	NC
PortA	3221	3220	3219	3220	3220	3221	3219	3221	3220	3220	3219	3220	3221	3221	3220	3220	NC	NC	26	26	NC	NC	NC	NC	NC	NC	NC
PortB	3220	3220	3219	3221	3220	3220	3221	3218	3220	3222	3221	3219	3220	3221	3221	3220	NC	NC	25	26	NC	NC	NC	NC	NC	NC	NC
BMU-3	3218	3221	3220	3220	3220	3219	3220	3222	3217	3217	3220	3220	3220	3220	3216	3219	NC	NC	26	26	NC	NC	NC	NC	NC	NC	NC
PortA	3218	3221	3220	3220	3220	3219	3220	3222	3217	3217	3220	3220	3220	3220	3216	3219	NC	NC	26	26	NC	NC	NC	NC	NC	NC	NC
PortB	3218	3219	3221	3221	3218	3219	3221	3220	3220	3220	3220	3221	3219	3221	3220	3219	NC	NC	26	26	NC	NC	NC	NC	NC	NC	NC
BMU-4	Invalid	Invalid	Invalid	Invalid	Invalid	Invalid	Invalid	Invalid	Invalid	Invalid	Invalid	Invalid	Invalid	Invalid	Invalid	Invalid	NC	NC	Invalid	Invalid	NC	NC	NC	NC	NC	NC	NC
PortA	Invalid	Invalid	Invalid	Invalid	Invalid	Invalid	Invalid	Invalid	Invalid	Invalid	Invalid	Invalid	Invalid	Invalid	Invalid	Invalid	NC	NC	Invalid	Invalid	NC	NC	NC	NC	NC	NC	NC
PortB	Invalid	Invalid	Invalid	Invalid	Invalid	Invalid	Invalid	Invalid	Invalid	Invalid	Invalid	Invalid	Invalid	Invalid	Invalid	Invalid	NC	NC	Invalid	Invalid	NC	NC	NC	NC	NC	NC	NC

## 8. Appendix2

### 8.1. Abnormal Situation Addressing

◆ What if the system does not work properly after power on?

A: The most direct way is to check the LCD Displaying of the inverter, through the LCD Displaying to find the fault phenomenon, causes can be roughly analyzed from the LCD Displaying interface prompt alarm, protection, fault, and other information, it can also provide necessary reference for further testing.

◆ What are the Battery Failures including?

1) Sampling failure: analog front-end and main control chip communication failure. When the fault occurs, the charge and discharge function is turned off, and the fault alarm can be automatically cleared after the fault is cleared.

2) Temperature NTC failure mainly detects whether the temperature NTC is short-circuited or disconnected. When the fault occurs, the charge and discharge function is turned off, and the fault alarm can be automatically cleared after the fault is cleared.

3) Cell failure: the voltage difference of the cell exceeds 1V, or the difference between the total voltage detection voltage and the sum of single cell voltage is more than 5V, or the minimum voltage is less than 0.5V. The voltage sampling line disconnect also reports the same fault. When the fault is cleared, the fault alarm can be automatically cleared.

## 8.2. Product Responsibilities and Consulting

- ◆ We will not be liable for the accidents resulting from operation breaking this specification and user manual.
- ◆ We will not send separate notice, provided that the contents of this specification are changed due to improvement of product quality or technological upgrading, if you want to understand the latest information of this product, please contact us.
- ◆ The shelf life of this product is within 60 months after it is delivered, we will maintain the product, which is in the warranty period for free of charge, if it has any product quality problems within the specified operation range, we may replace the relevant parts if we fail to maintain it.
- ◆ To achieve the purpose of sustainable use without performance reduction, our after-sales service personnel will propose the specific maintenance and troubleshooting methods in case of any questions, please contact us.

WARRANTY CARD			
Product Name		Model Number	
BATCH NO.		Shipping Date	
The Buyer		Phone	
Address			
<p>If a device becomes defective during the agreed warranty period, please report the defective device situation to the original manufacturer with this warranty card. Supplier or end users required to send the warranty claim form to the original manufacturer or authorized service partner with all the necessary information. Customers must present this warranty card, battery purchasing invoice, extension warranty letter if applicable, and other related materials as well if required. It is the responsibility of the warranty holder to substantiate the warranty claim and show that the conditions are met. Please note the original manufacturer reserve the ultimate explanation right on this warranty card.</p>			

**THANK YOU FOR CHOOSING**

**LET'S DEVELOP TRUST AND BUSINESS**



**Since 2003, BSLBATT provides electric energy more efficiently and reliably as best solution. Powerwall charges by day and powers at night for residential solar system with compact, affordable, and easy installation features.**

**BSLBATT Battery - Solar**

[inquiry@bsl-battery.com](mailto:inquiry@bsl-battery.com)

**+86-752 2819 469**



**Building 1, Zhongkai Innovation Base of Lihe Science and Technology, Huizhou,  
Huizhou City, Guangdong Province, China**